

*INCH-POUND

MIL-PRF-63460D
W/INT. AMENDMENT 7
26 October 2005
USE IN LIEU OF
MIL-PRF-63460D
W/AMENDMENT 6
24 July 1995

PERFORMANCE SPECIFICATION

LUBRICANT, CLEANER AND PRESERVATIVE FOR WEAPONS AND WEAPONS SYSTEMS

* This specification is approved for interim use by the US Army Armaments Research, Development and Engineering Center (ARDEC). Other activities of the Department of Defense may use this interim amendment or may continue using MIL-PRF-63460D(6).

1. SCOPE

* 1.1 Scope. This specification describes the performance requirements and verification methods for Lubricant, Cleaner and Preservative for Weapons and Weapons Systems (CLP). These products are for use in cleaning, lubricating and short term (see 6.11) preservation of weapons, both small and large caliber, operating within the temperature range of -54° to +65.5°C, (See 6.1). The lubricant is identified by Military Symbol CLP and NATO Code Number S-758.

* 1.2 Classification. CLP is of the following types, as specified (see 6.2)

- * Type I. General Environments
- * Type II. Extreme Desert Environment

2. APPLICABLE DOCUMENTS

* 2.1 General. The documents listed in this section are specified in sections 3 or 4 of this specification. This section does not include documents cited in other sections of this specification or recommended for information or as examples. While every effort has been made to ensure the completeness of this list, document users are cautioned that they must meet all specified requirements of documents cited in sections 3 and 4 of this specification, whether or not they are listed.

2.2 Government documents.

* 2.2.1 Specifications, standards and handbooks. The following specifications, standards, and handbooks form a part of this document to the extent specified herein. Unless otherwise specified, the issues of these documents are those cited in the solicitation or contract.

* Comments, suggestions or questions on this document should be addressed to: Commander, US Army ARDEC. ATTN: AMSRD-AAR-AIS-SS, Picatinny, NJ 07806-5000. Since contact information can change, you may want to verify the currency of this address using the ASSIST Online database at <http://assist.daps.dla.mil>.

FSC 9150

DISTRIBUTION STATEMENT A. Approved for public release; distribution is unlimited.

FEDERAL SPECIFICATIONS

- O-E-751 - Ether, Petroleum. Technical-grade
- O-M-232 - Methanol (Methyl Alcohol)
- P-D-680 - Dry Cleaning Solvent
- QQ-A-250/4 - Aluminum Alloy 2024, Plate and Sheet
- QQ-A-671 - Anode, Cadmium
- QQ-B-626 - Brass, Leaded and Nonleaded, Rod, Shaped, Forgings and Flat Products with Finished Edges (Bar and Strip)
- QQ-C-576 - Copper, Flat Products with Slit, Slit and Edge-rolled Sheared Sawed or Machined Edges (Plate, Bar, Sheet and Strip)
- QQ-M-44 - Magnesium Alloy Plate and Sheet (AZ31B)
- TT-N-95 - Naphtha, Aliphatic

FEDERAL STANDARDS

- FED-STD-313 - Material Safety Data Sheets, Preparation and the Submission
- FED-STD-791 - Lubricants, Liquid Fuels, and Related Products; Methods of Testing

DEPARTMENT OF DEFENSE SPECIFICATIONS

- MIL-A-18001 - Anode, Corrosion Preventive, Zinc, Slab Disc and Pod Shaped
- MIL-P-51408 - Paper, Chemical Agent Detector, VGH, ABC-M8
- MIL-P-51493 - Paper, Chemical Agent Detector: M9
- MIL-P-51518 - Paper, Chemical Agent Detector, M9

(Copies of these documents are available from the Standardization Document Order Desk, 700 Robbins Avenue, Building 4DPhiladelphia, PA 19111-5094, or online at <http://assist.daps.dla.mil>.)

* 2.2.2 Other Government documents, drawings, and publications. The following other Government documents, drawings and publications form a part of this document to the extent specified herein. Unless otherwise specified, the issues are those cited in the solicitation or contract.

U S ARMY DEVELOPMENTAL TEST COMMAND

- * TOP 3-2-045 Automatic Weapons, Machine Guns and Hand and Shoulder Weapons

(This document may be ordered from the US Army Developmental Test Command, ATTN: Publications, 314 Longs Corner Road, Aberdeen proving Ground, MD 21005-5005 or online at <http://www.dtc.army.mil/publications/topsinindex.aspx>.)

* 2.3 Non-Government publications. The following document(s) form a part of this specification to the extent specified herein. Unless otherwise specified, the issues of the documents are those cited in the solicitations (see 6.2).

ASTM INTERNATIONAL

- ASTM A109 - Steel, Carbon, Cold—Rolled Strip
- ASTM D56 - Flash Point by Tag Closed Tester
- ASTM D92 - Flash and Fire Points by Cleveland Open Cup
- ASTM D97 - Pour Point of Petroleum Oils

- ASTM D445 - Kinematic Viscosity of Transparent and Opaque Liquids (and the Calculation of Dynamic Viscosity), Test for
- ASTM D1748 - Rust Protection by Metal Preservatives in the I-Humidity Cabinet, Test for
- ASTM D2670 - Wear Properties of Fluid Lubricants (Falex Method), Measuring
- ASTM D4057 - Manual Sampling of Petroleum and Petroleum Products
- ASTM D4172 - Wear Preventive Characteristics Of Lubricating Fluid (Four-Ball Method)
- ASTM D4177 - Automatic Sampling of Petroleum and Petroleum Products

* (Copies of these documents may be ordered at www.astm.org or from the American Society of Testing and Materials, 100 Barr Harbor Drive, West Conshohocken, PA 19428-2959)

(Industry association specifications and standards are generally available for reference from libraries. They are also distributed among technical groups and using Federal agencies).

* 2.4 Order-or precedence. In-the event of a conflict between the text of this specification and the references cited herein, the text of this specification shall take precedence. Nothing in this document, however, supersedes applicable laws and regulations unless a specific exemption has been obtained.

3. REQUIREMENTS

3.1 Qualification. Formulations furnished under this specification shall be products which are qualified for listing on the applicable qualified products list at the time set for opening of bids (see 6.3).

3.1.1 Re-qualification. Any changes in the formulation or processing of a qualified product will necessitate its re-qualification. CLP supplied under contract shall be identical, within manufacturing tolerances, to the approved qualification sample. The Qualifying activity may, at its discretion, request complete re-qualification testing or require only partial re-qualification in order to determine the significance, impact and acceptability of any proposed formulation change, manufacturing process or change in manufacturing location.

3.2 Material. The ingredients of CLP shall be of a grade and quality which have been shown to be suitable for the intended purpose and which will produce a lubricating, cleaning and preserving formulation conforming to the requirements of this specification. CLP shall contain no graphite or powdered metals.

3.2.1 Product formulation. Preferably at the time of “application for qualification testing” but no later than the date of initiation of such testing, the lubricant manufacturing or distributing source of supply shall submit to the Government activity identified in 6.3 a detailed quantitative description of the product formulation, identifying each constituent material, percentage used in finished product and the manufacturing source of supply of each component (solvent, base oil, additive etc). The product formula as furnished to the Qualifying activity will be held in strictest confidence, filed in a secure file identified “For Official Use Only”. Any change to the product formulation so identified and filed, without first alerting the Qualifying activity identified in 6.3 accordingly, shall be cause for immediate removal from the Qualified Products List. The qualifying activity will perform an infrared spectrophotometric scan of sample submission and file same with formulation. The qualifying activity, at its discretion, will employ the filed scan to examine product samples taken from lot submissions for the periodic re-evaluation tests (see 4.5.2.1).

3.2.2 Ozone depleting substances (ODSs). CLP shall contain no Class I ozone depleting substances (See 6.14) as formulation ingredients.

* 3.3 Physical and chemical requirements. Unless otherwise specified, both Type I & Type II CLPs shall conform to the respective requirements specified in Table I and in 3.3 through 3.12 when tested with applicable test methods in Section 4.

TABLE I. Requirements

<u>Properties</u>	<u>Values</u>
Flash point, min C (F)	65.5° (150°)
Pour point, max C (F)	-59° (-75°)
Viscosity, kinematic, centistokes	
at 40° C (104° F), mm	9.0
at -54° C (-65° F) max	3700
Wear preventive characteristics,	
avg., scar diameter mm, max	0.8
Falex load carrying capacity, jaw	
* load, pounds, minimum	500

3.4 Firing residue removal. Upon completing three replicates, CLP shall remove a minimum average of 80% of the residue remaining after the ignition of WC 844 propellant (see 6.7) as used in 5.56mm cartridges.

3.5 Corrosion. CLP shall not produce visual evidence of pitting, etching, dark discoloration, or a weight change in excess of the following (see 4.5.3):

<u>Metal</u>	<u>Milligrams per square centimeter</u>
Zinc	1.5
Aluminum	0.2
Brass	1.0
Steel	0.2
Copper	1.5
Magnesium	0.5
Cadmium	1.5

3.6 Corrosion-protection.

3.6.1 Humidity resistance. After a minimum of 900 hours exposure in a humidity cabinet, not more than three corrosion dots none of which exceeds one millimeter in length, width, or diameter, shall be evident on the test panels. The total of such corrosion dots on all three test panels shall not exceed three. Corrosion on the outer 6.4mm of the panels shall not be cause for rejection (see 4.10).

3.6.2 Salt-spray resistance. After a minimum of 100 hours exposure to a spray of 5-percent salt solution, not more than three corrosion dots, none of which exceeds one millimeter in length, width, or diameter, shall be evident on any of the test panels. The total of such corrosion dots on all three test panels shall not exceed nine. Corrosion on the outer 6.4mm of the panels shall not be cause for rejection (see 4.11)

3.6.3 Corrosion-protection from propellant reaction products. After having been exposed to the ignition of WC844 propellant powder and 96 hours conditioning at 49±2°C (120°±5°F) and 100% Relative Humidity no rust spots 2mm or larger involving visible pitting or etching of the metal shall be evident on any of three humidity cabinet test panels. Rust spots occurring within 3mm (1/8") of the edges of the test panel shall not be cause for failure (see 4.12).

3.7 Water displacement and water stability. CLP, after storage in the static humidity chamber for one hour, shall satisfactorily displace water as evidence by the absence of rust, mottling, or other abnormal surface stains on the test panels (see 4.13).

3.8 Residue and fluidity at low temperatures. The residue remaining after evaporation at 54.4°C (130°F) shall not be tacky and shall permit movement at -54°C (-65°F) when tested as specified in 4.14.

3.9 Interference with chemical agent detector paper. CLP applied to and allowed to soak into chemical agent detector papers shall cause no discoloration, within the limits described in 4.15, in the stained portion of the paper. A coloration in the liquid droplet portion shall not be cause for failure. CLP shall be tested using chemical agent detector papers specified in 6.5 and in accordance with 4.15.

3.10 Toxicity. CLP shall have no adverse effect on the health of personnel when used for its intended purpose. Questions pertinent to this effect shall be referred by the contracting activity to the appropriate departmental medical service who will act as an advisor to the contracting agency (see 6.1.). The supplier shall furnish the qualifying activity (see 6.3) with all the information necessary to evaluate the safety of the product (see 4.16). This shall include safety data sheets conforming to FED-STD-313.

* 3.11 Workmanship. After shaking until all visible residue has been removed from the bottom of a translucent unit container, but for a period of time not to exceed 30 seconds, CLP shall be uniform in color and appearance when examined by reflected light.

* 3.12 Weapon performance.

* 3.12.1 Type I and II CLPs. Both types of CLP shall provide cleaning, lubricating and preservative characteristics necessary to assure continuous weapon (M60, 7.62mm Machine Gun) performance in cold and dusty environments, and when exposed salt water immersion. Stoppage of the Automatic Weapon attributable to CLP, or a reduction in the rate of fire of more than 15% of the original rate, shall constitute performance failure (see 4.18).

* 3.12.2 Type II CLP only. In additions to the operating environment requirements of 3.1.1, Type II CPL shall provide sufficient lubricating properties to assure continuous weapons performance (M249, 5.56mm Machine Gun) for firing 500 rounds after extended exposure to very fine dust. No more than four Class 1 stoppages, and zero Class 2 or 3 stoppages attributable to the CLP are allowed. (see 4.18.3.2)

*4. Verification

* 4.1 Responsibility for inspection. Deleted.

* 4.2 Lot, 4.2.1 Production lot, and 4.2.2 Packaged lot. Deleted (see 6.11)

4.3 Sampling for tests. Take samples for tests in accordance with ASTMs D4057 or D4177, as applicable.

4.4 Inspection.

4.4.1 Inspection of material. Perform inspection of material in accordance with Method 9601 of Fed-Std-791.

* 4.4.2 Examination of filled containers. Examine samples taken in accordance with 4.3 for compliance with MIL-STD-290 with regard to fill, closure, sealing, leakage, and marking requirements. Reject any container having one or more defects or under the required fill. Container material shall be of a density sufficient to prevent migration of the product or any constituents through the container. Container shall be pretreated to insure that printed identification will properly adhere and will not be removed by the product.

4.5 Classification of inspection.

- a. Qualification inspection
- b. Quality conformance inspection

4.5.1 Qualification tests. Qualification inspection consists of tests for all of the requirements specified in Section 3.

4.5.1.1 Qualification samples. The qualification sample shall consist of four 1-gallon containers of the finished products and, in addition, if the final formulation of the product contains solid materials, a one-half gallon sample shall be provided identical in nature to the final product but without the addition of any solids. The sample will be accompanied by data responsive to 4.16. Sample and report shall be furnished to the address indicated in 6.3.

* 4.5.1.2 Retention of qualification & 4.5.2 Periodic qualification re-evaluation. Deleted.

4.5.2.1 Periodic qualification re-evaluation tests. The re-evaluation of products being manufactured under current contract shall consist of what tests the Qualifying activity determines necessary for product identity, verification and evaluation. Delivery of a product per current contract shall not be delayed pending completion of this test and inspection. The results obtained shall be considered indicative of product quality and production consistency. Failure of a product sample to pass a periodic qualification re-evaluation shall require the acceptance and further shipment of a product to be discontinued until the manufacturer has corrected the conditions which led to the failure and has furnished data, documentation or affidavit to that effect. Further product failure or nonconformance shall constitute a basis for lot rejection and subsequent removal from the Qualified Product List.

4.5.3 Quality conformance inspection. Quality conformance inspection consist of tests for all the requirements in section 3 except for weapon performance (3.12) and Humidity Resistance (3.6.1)

4.5.3.1 Rejection of lots. If a product sample fails to meet any of the specified tests, the lot represented by the sample shall be rejected.

4.6 Test methods. Perform in accordance with the applicable methods listed in Table II and in 4.7 through 4.19.

TABLE II. Test Methods

<u>Test</u>	<u>ASTM Method No.</u>
Flash point	D56 <u>1/</u>
Pour point	D97
Viscosity, kinematic	D445 <u>2/</u>
Wear preventive characteristics	D4172 <u>3/</u> (Test Condition B)

1/ If the flash point is over 175°F (79.4°C), use the Cleveland Open Cup method, D92.

2/ Use this method with the following exception:

The kinematic viscosity shall be determined on that portion of the product containing no solid materials. Where periodic qualification re-evaluation tests or quality conformance tests are conducted on lots received from a manufacturer whose product contains particulate matter, the product must be centrifuged and pressure filtered using a Gelman Filter-Gauge, .45 micron pore diameter and .2 micron pore diameter, stack (top to bottom).

3/ Use this method with the following exceptions:

- a. Use a sample of 10 ± 0.5 milliliters.
- b. Make 6 duplicate runs and report average of results.

4.7 Falex load carrying capacity. Use the Falex Lubricant Tester to determine the load carrying capacity of the product. A description of the Falex machine and the calibration thereof may be found in ASTM D2670. Use standard Falex jaw blocks, AISI 1137 steel, and standard Falex pins, AISI 3135 steel, in accordance with ASTM D2670. Thoroughly clean the blocks and pins in warm petroleum naphtha conforming to TT-N-95, then methanol conforming to O-M-232, Grade A, then air dry them in a desiccator. Insert the blocks in the jaws of the tester and place the pin in the chuck. Install the shear pin to hold the test pin in place. Apply a thin film of the test compound to the V-area of the blocks and to the mating surface only of the test pin. CLP on the test pin above the V-blocks acts as a reservoir and may give false results. The excess fluid from the bottom of the test pin and blocks is removed by blotting with tissue. Close the jaws, install the loading device and 4500 lb gauge and start the tester. Increase the jaw load from zero to 250 pounds by means of the eccentric arm and ratchet wheel. Disengage the eccentric arm, start the timer and allow the machine to run at this loading for a 3 minute break-in period. Re-engage the eccentric arm, start the timer and allow the machine to run at this load for 1 minute. Repeat this loading sequence to raise the jaw load to 500 pounds and operate at this load for 1 minute to determine compliance with 3.3. Perform test on three replicate samples allowing Falex machine jaws and chuck to cool to room temperature $20^{\circ} \pm 2^{\circ}\text{C}$ ($70^{\circ} \pm 5^{\circ}\text{F}$) prior to each run.

4.8 Firing residue removal. Weigh 5.0 ± 0.5 grams of WC844 propellant powder into a tared (T), clean porcelain evaporating dish (round bottomed type) of approximately 102mm (4 in) in diameter. Ignite the propellant with a Bunsen burner and allow dish to cool for 20 minutes. Invert the dish, rap it sharply several times against the table top and then blow it out with 15 psi stream of filtered air, through a hose of approximately 1.3cm (1/2 inch) diameter, to remove any non-adhering residue. The dish shall be held approximately 15cm (6 inches) from the end of the air hose. Weigh the dish (W_1) and add 25 ± 1 ml of the product and permit it to soak for 45 ± 3 min, at $54^{\circ} \pm 1^{\circ}\text{C}$ ($130^{\circ} \pm 2^{\circ}\text{F}$) in a convection oven. At the end of the 45 minute period, remove the dish and immediately swab the residue with a double layer of cotton gauze pad (see 6.8) wrapped around and fastened to the wide end of a No. 4 Coors porcelain pestle. The pestle should measure approximately 178mm (7 in) long by 52mm (2 1/16 in) at its widest point and weigh approximately 300 g. Swab the dish in both a circular and back and forth motion for a period of 90 sec. letting the weight of the pestle perform the actual removal of the residue. Do not apply any downward force to the pestle. After swabbing, decant the remaining oil and thoroughly wash the inside of the dish with 75ml of petroleum ether in accordance with O-E-751. Heat the evaporating dish to $54.4^{\circ} \pm 1^{\circ}\text{C}$ ($130^{\circ} \pm 2^{\circ}\text{F}$) for 30 ± 2 minutes, cool to room temperature and weigh (W_2). Calculate the percent of residue removed by the equation:

$$\% \text{ residue removal} = 100 \times \frac{W_1 - W_2}{W_1 - T}$$

Where:

W_1 - first gross weight of residue

W_2 - gross weight after heating

T - tare of evaporating dish

4.9 Corrosion. Use Test Coupons measuring 25 by 51 by 6.4mm(1 by 2 by 1/4 inches) made from the following metals for the corrosion test:

<u>Metal</u>	<u>IAW specification</u>
Zinc	MIL-A-18001
Aluminum	QQ-A-250/4
Brass	QQ-B-626, composition 22 (leaded brass)
Steel	ASTM A109
Copper	QQ-C-576
Magnesium	QQ-M-44, AZ31B (Condition H24 or H26)
Cadmium	QQ-A-671

Polish all surfaces of the Test Coupons using progressively finer abrasive paper, finishing with a 240-grit polishing medium. Hold the Test Coupons with tongs or filter paper. Do not touch them with the fingers. The use of a slow speed horizontal metallurgical polishing wheel is convenient, with the final polishing being done with 240-grit aluminum oxide paper or cloth moistened with dry cleaning solvent conforming to P-D-680. The use of “wet or dry” papers is prohibited. Test Coupons shall be cleaned by swabbing in hot naphtha with a final rinse in warm anhydrous methanol conforming to grade A of O-M-232 (use 95 percent ethanol for the magnesium specimen). The Test Coupons shall be held in a manner to avoid contact with the operator’s hands. After weighing, place the test coupons, in the order listed above, in a mason jar measuring approximately 88.9mm (3 1/2 in) in diameter and 95.25mm (3 3/4 in) deep and having a screw cap. Stand the test coupons on one 6.4mm (1/4 in) edge in a circular pattern so that the 25mm (1 inch) length is parallel to the jar circumference as indicated in Figure 1. Position the coupons along the jar circumference so that there is an approximately equal spacing between each. The test coupons shall be covered with enough of the product supplied, containing no solid particles, so that the tops of the coupons are at least 6mm (1/4 inch) below the surface of the product. Screw the jar lid closed and place the jar in a convection oven maintained at $54.4 \pm 1^\circ\text{C}$ ($130^\circ \pm 2^\circ\text{F}$) for a period of 7 days \pm 15 minutes. Upon completion of the test, remove the CLP and any loose corrosion products from the specimens by swabbing with surgical gauze pads moistened with naphtha, then with methanol (use 95 percent ethanol for the magnesium), and follow by clean solvent rinses. Re-weigh the specimens and calculate the weight loss or gain in milligrams per square centimeter.

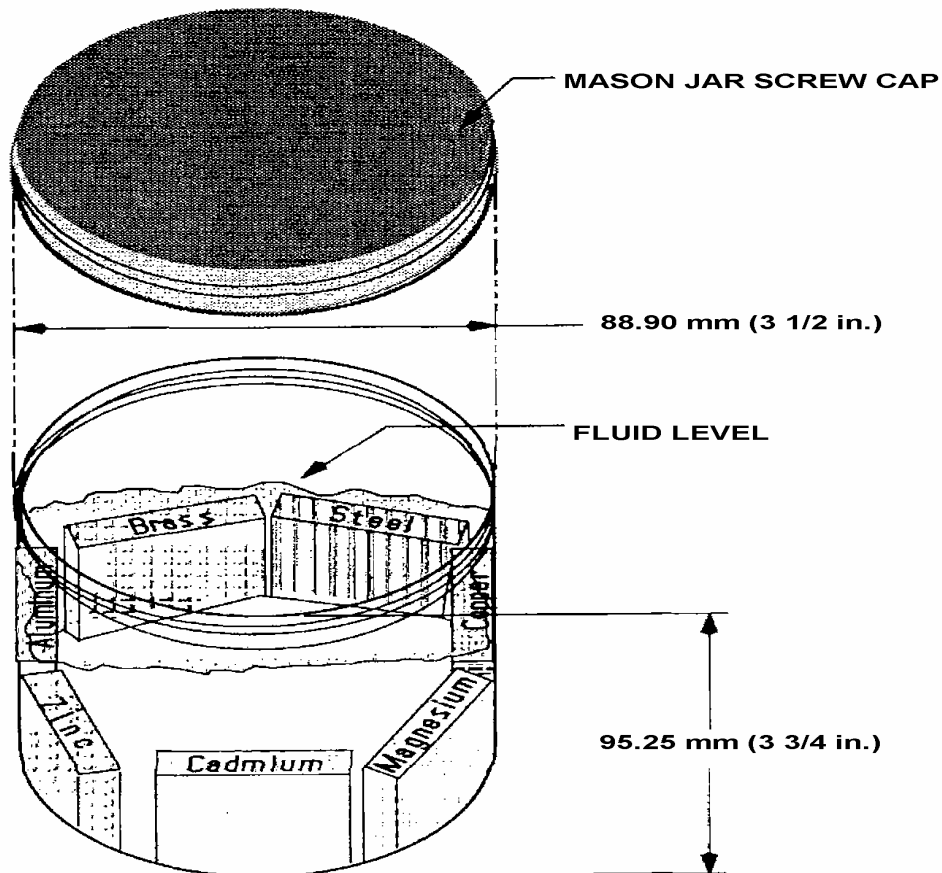

FIGURE 1. Corrosion Test

CAUTION: The Corrosion test should not be performed on a material with a “Flash Point” that is not in conformance to that required [65.5C(150F)]. Therefore, it is essential that Flash Point be established prior to the “Corrosion” test.

4.10 Corrosion protection, humidity cabinet. Test the CLP for humidity cabinet corrosion protection in accordance with Method 5329 of FED-STD-791.

* 4.11 Corrosion protection, salt spray resistance. Test the CLP for salt spray resistance (5 percent solution) in accordance with Method 4001 of FED-STD-791. Use three test panels prepared in accordance with FED-STD-791, Method 5329, materials and procedures sections, with the exception that, in place of the silica sand detailed in the materials section, 120 grit white aluminum oxide shall be used.

4.12 Corrosion-protection from propellant reaction products. Humidity cabinet corrosion test panels conforming to ASTM Method D1748, Appendix Section A1.10 shall be used in the test. Thoroughly clean three panels first in heated petroleum naphtha conforming to TT-N-95 and then in heated methanol conforming to O-M-232. Solvents shall be heated sufficiently so that the solvent will evaporate from the panels immediately upon withdrawal from the solvent baths. Place the panels in a dessicator and after they have cooled, slosh each panel in a beaker of the test oil for a period of one minute and, suspending them from a rack, allow them to drain for a period of two hours. After the two hour period slosh each panel for one minute in a beaker containing a solution of 5% sodium chloride by weight dissolved in distilled water. Drain the panels again for a period of fifteen minutes. While the panels are draining, weigh out 3 ± 0.1 grams of WC-844 propellant powder into each of three shallow-form porcelain evaporating dishes measuring 120mm in diameter with 195 ml capacity (Coors #60234). Concentrate the powder into a strip measuring approximately 25mm wide across the bottom of the dish. After completion of the 15 minute drain period place a panel across the top of a test fixture constructed of four humidity cabinet test panels fastened together to form a box-like structure opened at top and bottom with interior dimensions measuring 10.2cm (4 inches) in length, 4.45 cm (1 3/4 inches) in width and 5.1cm (2 inches) in height. Place the fixture with the test panel on it across the rim of the evaporating dish centered over and parallel to the strip of propellant and ignite the powder so that one face of the test panel is exposed to the burning propellant. Repeat this operation on the other two panels and then suspend the three panels in an environmental chamber (see 6.12) maintained at $49^{\circ} \pm 2^{\circ} \text{ C}$ ($120^{\circ} \pm 5^{\circ} \text{ F}$) and 100% relative humidity. The panels should be suspended side by side forming one row- so that the test surfaces are facing the front of the chamber and the distance from the rear of the chamber to each panel is 350mm (13 3/4 inches) and the distance from the chamber floor to the bottom of the panels is 430mm (17 inches). After a period of 96 hours remove the test panels from the chamber, wipe the panels lightly with a soft cloth or tissue paper soaked with petroleum ether and observe for any rusting on the test face of the panels.

4.13 Water displacement and water stability. Conduct the water displacement and water stability test in accordance with FED-STD-791, Method 3007 except that the test shall be made only on the compound-water mixture.

4.14 Residue and fluidity at low temperature. Twenty-five milliliters of the product, supplied without solids, shall be placed in a flat bottom Petri dish, approximately 10 centimeters in diameter, and heated in an oven maintained at $54.4^{\circ} \pm 2^{\circ} \text{ C}$ ($130^{\circ} \pm 5^{\circ} \text{ F}$) for 40 hours. At the end of the heating period, the sample shall be cooled to $25^{\circ} \pm 2^{\circ} \text{ C}$ ($77^{\circ} \pm 3^{\circ} \text{ F}$) and examined for tackiness by touching the residue. A visual examination shall be made for particle contamination. A sufficient quantity of the residue shall be placed upon the end of a glass slide approximately 25 by 76mm (1 by 3 inches). Another slide shall be placed over the residue so that an overlap of approximately one square inch is formed. A one kilogram weight is placed on the test area for 30 seconds. The weight is then removed and the slides subjected to $-54^{\circ} \pm 3^{\circ} \text{ C}$ ($-65^{\circ} \pm 5^{\circ} \text{ F}$) for 24 hours. While at a temperature of $-54.8^{\circ} \pm 3^{\circ} \text{ C}$ ($-65^{\circ} \pm 5^{\circ} \text{ F}$), and using insulated gloves for hand protection, the two slides shall be separated by hand using a sliding action. If no movement is detected within a period of one second the material shall be rejected

4.15 Interference with chemical agent detector paper. This test shall be conducted using three different 3 inch strips each, of ABC M8, per MIL-P-51408, and M9, per MIL-P-51493 or MIL-P-51518, Chemical Agent Detector Papers. Shake the CLP container for 10 to 15 seconds before placing the compound on the paper. Dip a nylon bristle tooth brush into the CLP container and using a dull knife

blade brushed across the bristles, spatter droplets of the product onto the detector paper. The strips should be observed for color change after 5 minutes from the time of placing the CLP on the paper. The CLP shall be considered unacceptable if the stain portion (excluding droplet portion) of the M8 paper shows any discoloration (pink, orange, red-brown, yellow, green and blue are examples of unacceptable colors), or if the stain portion of the M9 paper shows any red coloration (any shade of red is unacceptable, including pink, red, red-brown, red-purple).

- * 4.16 Toxicity. Objective evidence of product conformance with 3.10 shall be examined.
- * 4.17 Ozone depleting substances. Objective evidence of conformance with 3.2.2 shall be examined.
- * 4.18 Workmanship. A 4 oz translucent container of product shall be shaken IAW 3.11 and visually inspected for conformance. Failure of residue on bottom of container to disperse after shaking container for 30 seconds shall be cause for rejection.
- * 4.19 Weapon performance. The overall performance of the candidate product shall be determined by utilizing the Machine Guns, 7.62mm M60 (for Type I qualification) and 5.56mm M249 (for Type II qualification, only). Weapons that have been fired less than 5000 rounds, or weapons with a used receiver but with an all new operating group, shall be used. Linked belts of ammunition, as used hereafter, shall be “combat mix”, (4 ball, 1 tracer).
 - * 4.19.1 Inspection. Select a Machine Gun. Disassemble and note the headspace, bore diameter, chamber dimensions, firing pin protrusion and indentation, trigger pull and overall condition. While disassembled, clean all traces of lubricant and dirt by washing with a volatile mineral spirits, such as P-D-680 Dry Cleaning Solvent or TT-N-95 Naphtha. After complete removal of the solvent from all surfaces of the weapons by use of a water-free air hose or by air-drying, lubricate each weapon with the candidate product in accordance with procedures specified in the operators manual. A lint-free patch shall then be used to remove excess CLP from gun components. The gun shall then be reassembled and bench tested for operational use. The gun shall then be test fired for 20 rounds in an ambient temperature of 50° to 100° F (10° to 37.8° C) and the cycle rate of fire recorded. Upon satisfactory completion of the ambient temperature test, the weapon shall be disassembled, cleaned, lubricated and allowed to condition at ambient temperature for 24 hours prior to the next phase of testing.
 - * 4.19.2 Cold temperature test (Type I & II). With the bolt in the rearward (firing) position and the selector level set on “safe” the M60 MG shall be loaded with 50-round belt of ammunition and conditioned at $-54^{\circ} \pm 2^{\circ}\text{C}$ ($-65^{\circ} \pm 5^{\circ}\text{F}$) for 16 ± 1 hours. The weapon shall then be placed in the firing fixture, the selector lever set on “fire” and the entire 50 rounds fired with one pull of the trigger, recording the cyclic rate of fire. Reload the weapon as above and condition at $-54.5^{\circ} \pm 2^{\circ}\text{C}$ ($-55^{\circ} \pm 5^{\circ}\text{F}$) for an additional 3 hours. Fire the entire 50 rounds and again record the rate of fire.
 - * 4.19.3 Static dust test.
 - * 4.19.3.1 Types I & II CLP. The weapon (M60, 7.62mm Machine Gun) shall be disassembled, cleaned and lubricated with the candidate product. Three firing cycles of 7.62mm ammunition shall be fired in accordance with the procedures and specification of TOP-3-2-045 (M60 Machine Gun). Between each firing cycle, the weapon shall be stripped, cleaned and lubricated. The firing cycle consists of 200 rounds of Combat Mix (M60 Machine Gun). Cyclic rates will be determined during each cycle. Muzzle velocities of the last 10 rounds of each cycle will be recorded and critical dimensions again determined at the completion of the test.
 - * 4.19.3.2 Type II CLP. Weapons preparation, firing, and evaluation shall be the same as 4.19.3.1, except that the weapon used shall be the M249, 5.56mm Machine Gun. The application of TOP 3-2-045

shall be modified to use a sand/dust mixture consisting of 100% 140 mesh silica flour, instead of the sand mixture specified by the TOP used for 4.5.12.3.1, and dust dispenser exposure time shall be 15 minutes. One firing cycle of 500 rounds will be executed without cleaning or additional application of lubricant. More than four Class 1 stoppages or any Class 2 or Class 3 stoppages shall be cause for failure.

* 4.19.4 Salt water immersion test (Type I & II). Use the M60 Machine Guns previously fired in the Static dust test (4.19.3.1). The test will be conducted in accordance with the procedures and specifications of TOP 3-2-045 (M60 Machine Gun) except that a 5 percent salt water solution shall be used.

The Machine Gun and two (2) belts of 100 rounds will be immersed for sixty (60) seconds and after removal the salt solution drained from the bore. The full complement of 200 rounds will be fired; the first belt interrupted burst and the second belt continuous automatic burst. There will be no barrel change during this test.

Using clean ammunition repeat the firing cycles on the Machine Gun four (4) additional times on third, fifth, eighth, and tenth day following the first firing. Do not clean or add CLP during these additional firings. Between firing store the weapon in a humidity environment (a least 90 percent RH), IAW TOP 3-2-045 (M60).

5. PACKAGING

* 5.1 Packaging. For acquisition purposes, the packaging requirements shall be as specified in the contract or order (see 6.2) When actual packaging is to be performed by DoD or in-house contractor personnel, these personnel need to contact the responsible packaging activity to ascertain packaging requirements. Packaging requirements are maintained by the Inventory Control Point's packaging activity within the Military Service or Defense Agency, or within the military service's system commands. Packaging data retrieval is available from the managing Military Department's or Defense Agency's automated packaging files, CD-ROM products, or by contacting the responsible packaging activity.

6. NOTES

* (This section contains information of a general or explanatory nature that may be helpful, but is not mandatory)

* 6.1 Intended use. Both types of CLP covered by this specification are highly penetrating, mobile liquids and are intended for field application to satisfy the complete need of cleaning, lubricating, and short term preservation of both small and large caliber weapons. CLP facilitates the effective removal of firing residues, gums and other contaminants from weapon components while at the same time provides adequate lubrication and short term preservation for reliable, durable operation in all climatic conditions, and in temperatures ranging from -54 to 65.5 C. CLP may be used in lieu of MIL-PRF-372 (RBC), W-L-800 (PL-S), MIL-L-3150 (PL-M), MIL-L-14107 (LAW) and MIL-L-46000 (LSA) for specific applications where tests have shown it to be satisfactory in small and large caliber weapons.

6.1.1 Other uses. CLP may be used in other cleaning, lubricating, and short term preservative applications where tests have shown it to be satisfactory for that specific application.

6.1.2 Preservative and packaging application limitation. Products conforming to the requirements and tests of this specification should not be used for preservative applications where the intent is long-term storage, without contact and consultation with the responsible preparing activity indicated in 6.3. Due to the solvent systems common to CLP type formulations, caution should be exercised when using products-

conforming to this specification where, because of test or manufacturing schedules, process, facilities limitations, etc., opportunity or capability for proper ventilation of the treated surface, prior to sealing, is not practicable.

6.2 Ordering data. Procurement documents should specify the following:

- * a. Title, number, and date of this specification, and all reference documents cited in Section 2.
- * b. Type of CLP required (Type I or Type II)
- c. Quantity of lubricating oil required.
- d. Type and size of container (see MIL-STD-290)
- e. Level of preservation and packing (see MIL-STD-290).
- f. Toxicological Data Requirements (see 3.10 and 4.16)

* 6.3 Qualification. With respect to products requiring qualification, awards will be made only for products which are at the time set for opening of bids, qualified for inclusion in the applicable Qualified Products List whether or not such products have actually been so listed by that date. The attention of the suppliers is called to this requirement, and manufacturers are urged to arrange to have the products that they propose to offer to the Federal Government tested for qualification in order that they may be eligible to be awarded contracts or orders for the products covered by this specification. The activity responsible for the Qualified Products List is US Army Armament, Research Development and Engineering Center, Attn: AMSRD-AAR-AIS-SS, Picatinny, New Jersey 07806-5000.

6.4 Units of measure. In sections of this specification where U.S. customary units are given first with metric units in parenthesis, the U.S. customary units should be considered as the standard. Metric units have been rounded off and are not in many instances, precise equivalents of the U.S. units.

6.5 Chemical agent detector paper. ABC M8 and M9 Chemical Agent Detector Papers shall be used for test. For each lot of lubricant tested five booklets of MS paper and one roll of M9 paper will be required.

6.5.1 M8 and M9 availability. For the purpose of qualification testing, candidate manufacturing sources of supply may obtain samples of M8 and M9 papers from the Activity indicated in 6.3.

6.5.2 M8 and M9 chemical agent detector paper. For the purpose of candidate formula preparation intended for qualification testing, data on chemical make-up and listing of materials that are not compatible i.e., give false positive reaction, with M8 and M9 paper can be obtained from the Activity identified in 6.3.

* 6.6 National stock numbers. The following National Stock Numbers have been assigned to products covered by this specification:

<u>TYPE I</u>		<u>TYPE II</u>
9150-01-102-1473	0.5 oz plastic bottle	9150-01-530-0529
9150-01-079-6124	4 fl. oz. plastic bottle	9150-01-530-0533
9150-01-054-6453	1-pt. plastic bottle w/sprayer	9150-01-530-0546
9150-01-327-9631	1 liter bottle w/sprayer	9150-01-530-0559
9150-01-053-6688	1-gal. plastic bottle	9150-01-530-0567

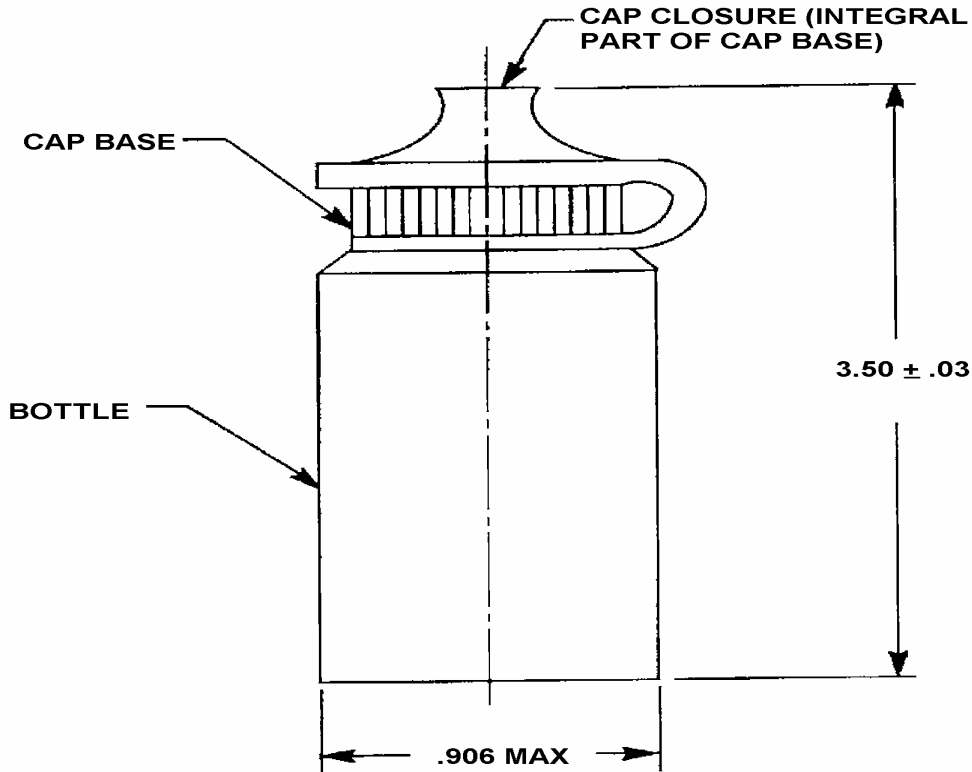

FIGURE 2. Bottle, 0.5Oz Cylindrical

NOTES:

1. Plastic, Polyethylene, Type I, Class H, Grade 2, Translucent, per L-P-390.
2. Bottle shall have a minimum capacity after oven drying of .68 fluid ounces when filled to overflow.
3. Thread shall be free from flash, rough parting lines and other defects which will interfere with proper seal.

6.7 WC 844 propellant. Propellant referenced in 3.4 and 3.6.3 and required for the performance of the test per 4.8 may be obtained upon request from the activity responsible for the Qualified Products List, as indicated in 6.3.

6.8 Cotton gauze pads. Commercial laboratories attempting to duplicate this test may use Webril Fandi-Pads 7 1/2" x 3 7/8" (unfolded), source: Kendel Co., Graphic Arts Products, Boston, MA 01201.

* 6.9 Changes from previous issue. Asterisks are used in this amendment to identify changes with respect to the previous issue.

6.10 Ventilation requirements. Due to the solvent systems that are often employed in CLP type formulations, field users should avoid opening CLP filled containers or application of CLP type products under conditions of limited ventilation, i.e., closed rooms, sealed vehicles.

6.111 Definitions.

6.11.1 Short term preservation. Period of time not to exceed 30 days.

6.11.2 Production lot. An indefinite quantity of a homogeneous mixture of product offered for acceptance in a single, isolated container, or manufactured in a single plant run, through the same

processing equipment, with no change in the ingredient materials in a 24 hour time period.

6.11.3 Packaged lot. An indefinite number of unit containers of identical size and type, offered for acceptance at one time, and filled with a homogeneous mixture of product manufactured in a single plant run, through the same processing equipment, in a 24 hour time period.

* 6.11.4 Classes of stoppages.

* 6.11.4.1 Class 1. A failure that may be operator immediately clearable within 10 seconds or less while following prescribed immediate action procedures.

* 6.11.4.2 Class 2. A failure that may be operator clearable requiring more than 10 seconds but not more than 10 minutes. Only the equipment and tools issued with the weapon may be used to clear the failure.

* 6.11.4.3 Class 3. A failure of a severe nature. The failure; (1) is operator correctable but requires more than 10 minutes, (2) operator cannot correct and requires assistance (no time limit), (3) requires higher level of maintenance, or authorized operator correction cannot be accomplished because of unavailability of necessary tools, equipment or parts.

6.12 Environmental chamber. The Environmental Chamber used is the Tenney Model # 15-10 Test Chamber. The interior of the chamber measures approximately 1219mm (48 inches) x 483mm (19 inches) x 483mm (19 inches). The bottom rear area of the chamber is recessed and contains a 203mm (8 inch) circulating fan whose center is 152mm (6 inches) from the bottom of the chamber and whose face is 533mm (21 inches) from the front of the chamber. The right side of the chamber contains a Sham (2 inch) circular humidity vent the center of which is 150mm (6 inches) from the rear of the chamber and 89mm (3.5 inches) from the top of the chamber. Controls on the exterior of the chamber permit individual settings for dry and wet bulb temperatures within the test chamber.

6.13 International standardization agreement. Certain provision of this specification are the subject of international standardization agreement (NATO STANAG 1135). When amendment, revision, or cancellation of this specification is proposed which would affect or violate the international agreement concerned, the preparing activity will take appropriate reconciliation action through international standardization channels, including departmental standardization offices, if required.

6.14 Class I ozone depleting substances. The identification of Class I ozone depleting substances must be in conformance to Section 602(a) of the Clean Air Act Amendments of 1990 (42USC 7671a) as identified in Section 326 of PL 102-484.

Custodian:
Army - AR
Navy - AS
Air Force - 11

Preparing activity:
Army - AR

(Project No. 9150-2006-004)

Review activities:
Army - ME,MD,SM -
DLA - GS
Air Force - 68